

*: Filettatura GAS

*: BSPP threaded

DN	Electric motor	d	L	H	L2	L3	L4	L5
1/4"	AOX-003	11	50	140	123	113	100	25
3/8"	AOX-003	12.7	50	140	123	113	100	25
1/2"	AOX-003	15	55	143	123	113	100	25
3/4"	AOX-003	20	71	149	123	113	100	25
1"	AOX-003	25	83	153	123	113	100	25
1"1/4	AOX-005	32	91	166	160	121	121	25
1"1/2	AOX-005	40	103	176	160	121	121	25
2"	AOX-005	50	120	183	160	121	121	25

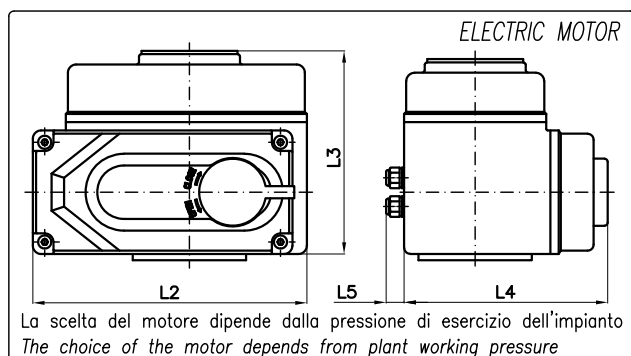

La scelta del motore dipende dalla pressione di esercizio dell'impianto
The choice of the motor depends from plant working pressure

Combinazione materiali standard - Standard materials Combination		
ITEM	DENOMINAZIONE DENOMINATION	MATERIALE MATERIAL
01	Body	Stainless steel CF8M ASTM A351
02	Ball	Stainless steel AISI316 UNI EN10088
03	Stem	Stainless steel AISI316 UNI EN10088
Nota: Combinazioni materiali non standard a richiesta Note: Non standard materials combinations on request		