

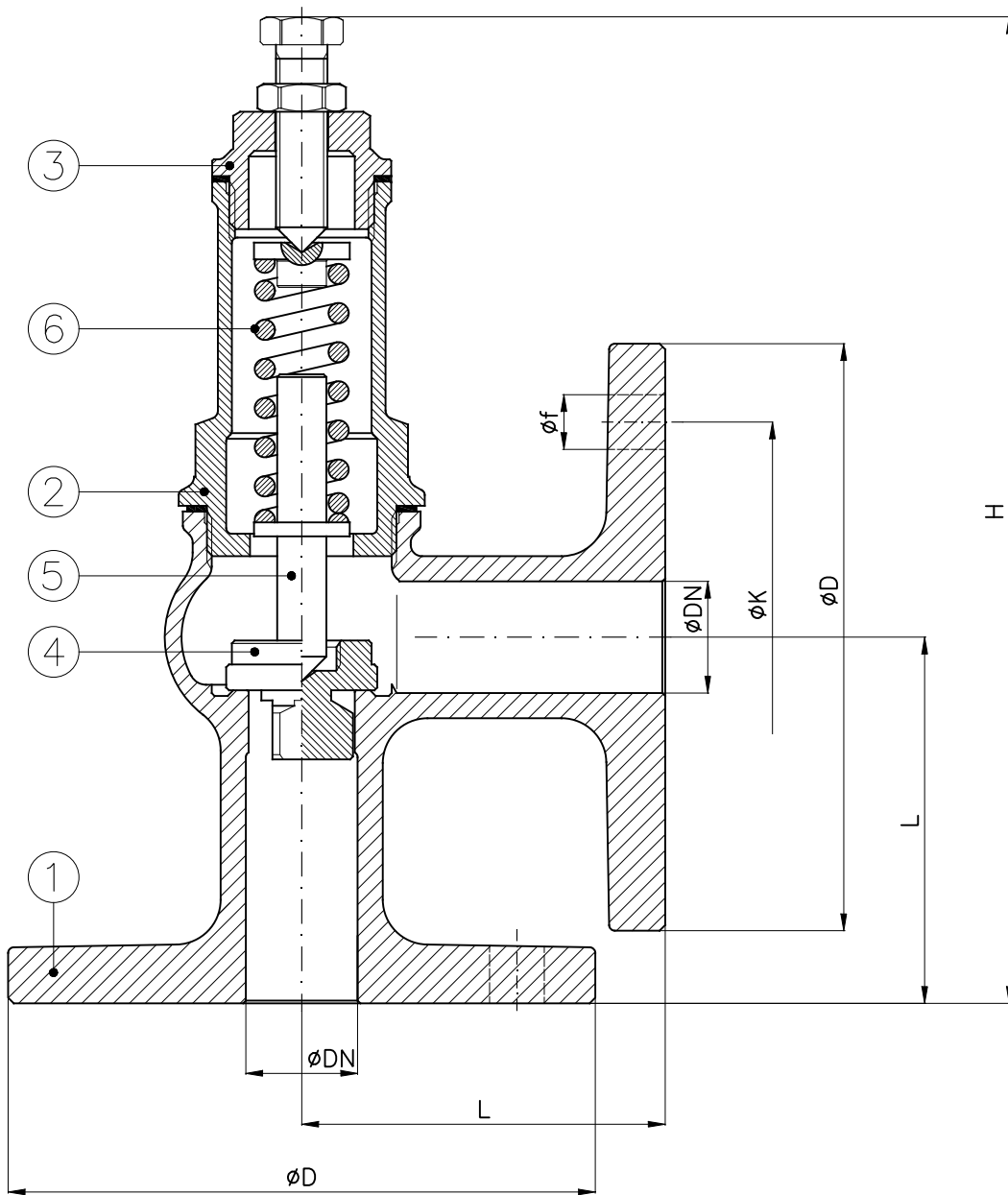

Conform to:
UNI EN1092

SEDE TEFLON
 PTFE SEAT

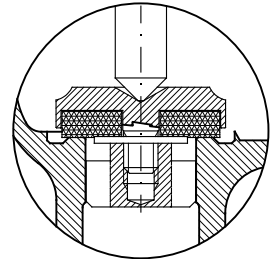

DN	H	L	D	K	f	Holes NO. f	Weight (Kg)
15	155	60	95	65	14	4	1.7
20	183	65	105	75	14	4	2.2
25	202	72	115	85	14	4	3.2
32	239	85	140	100	18	4	4.8
40	255	90	150	110	18	4	6.1
50	280	105	165	125	18	4	8.5
65	320	110	185	145	18	4	12.5
80	337	115	200	160	18	8	14.5
100	415	140	220	180	18	8	20

Combinazione materiali standard - Standard materials Combination		
ITEM	DENOMINAZIONE DENOMINATION	B/O MATERIALE MATERIAL
01	Body	Bronze UNI EN1982 G-CuSn5Zn5Pb5
02	Bonnet	Brass CW617N (OT58)
03	Plug	Brass CW617N (OT58)
04	Disc (DN15÷50)	Brass CW617N (OT58)
04	Disc (DN65÷100)	Bronze UNI EN1982 G-CuSn5Zn5Pb5
05	Stem	Brass CW617N (OT58)
06	Spring	Steel UNI EN10270
Nota: Combinazioni materiali non standard a richiesta Note: Non standard materials combinations on request		