

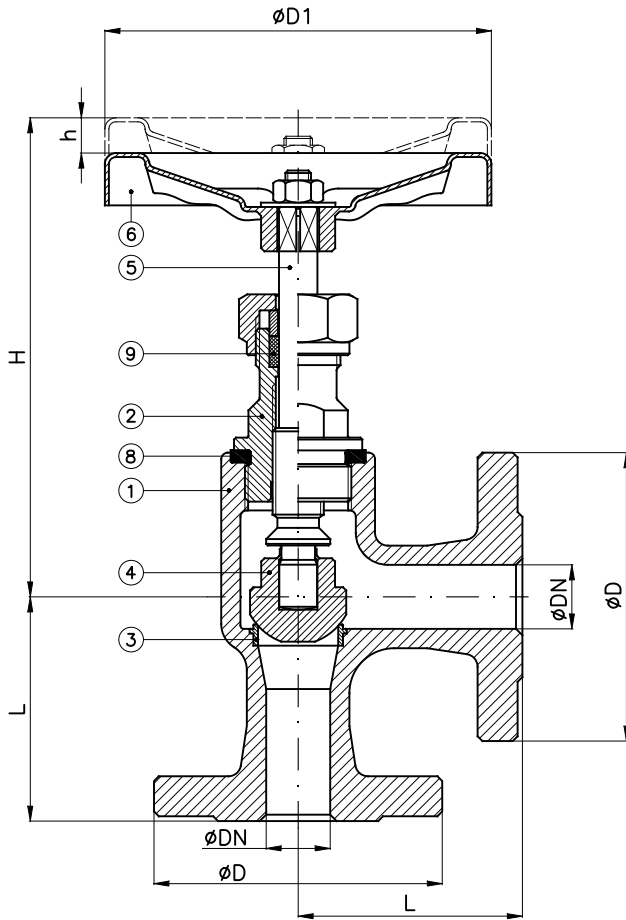

Conform to:
UNI EN1092

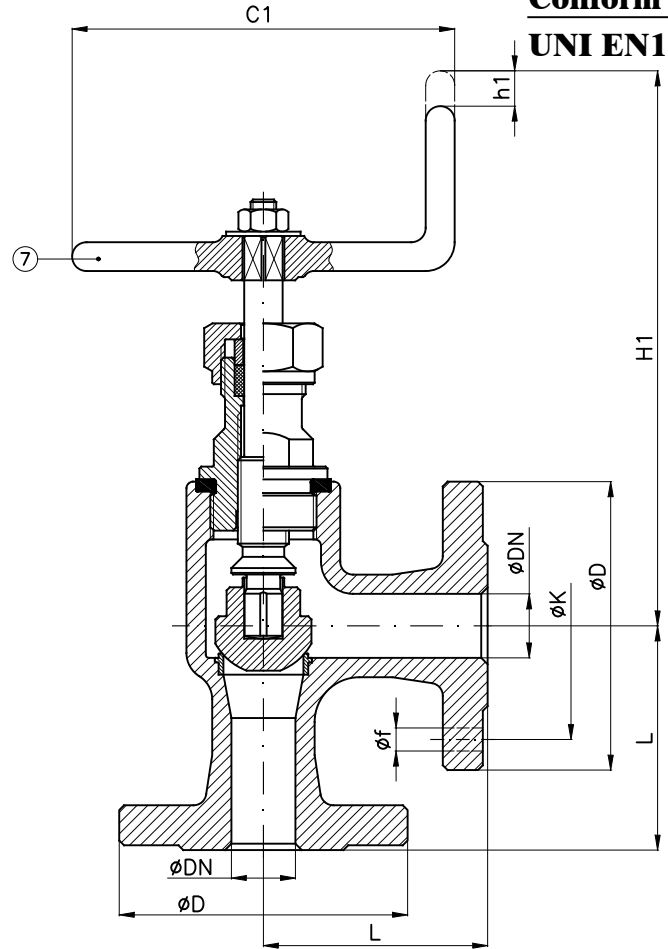

Tab.121.1A PN6
 comandata (SDSL)
 with fixed disc (SDSL) UNAV 9832



Tab.121.2A PN6
 semiautomatica (SDNR)
 with loose disc (SDNR) UNAV 9835

DN	C1	D1	H SDSL (~)	h SDSL	H1 SDNR (~)	h1 SDNR	L	D	K	f	Holes NO. f	Weight (Kg)
15	100	100	160	10	190	10	70	80	55	11	4	1.7
20	100	100	160	10	190	10	70	90	65	11	4	2
25	100	100	155	10	185	10	75	100	75	11	4	3
32	125	125	180	13	205	13	80	120	90	14	4	4

Combinazione materiali standard - Standard materials Combination				
ITEM	DENOMINAZIONE DENOMINATION	A/316 MATERIALE MATERIAL	A/B MATERIALE MATERIAL	CF8M/316 MATERIALE MATERIAL
01	Body	Cast steel GP240-GH UNI EN10213	Cast steel GP240-GH UNI EN10213	Stainless steel CF8M ASTM A351
02	Bonnet	Carbon steel GE240 UNI EN10293	Carbon steel GE240 UNI EN10293	Stainless steel AISI316 UNI EN10088
03	Body seat	Stainless steel AISI316 UNI EN10088	Stainless steel AISI316 UNI EN10088	Stainless steel AISI316 UNI EN10088
04	Disc	Stainless steel AISI316 UNI EN10088	Bronze UNI EN1982 G-CuSn5Zn5Pb5	Stainless steel AISI316 UNI EN10088
05	Stem	Stainless steel AISI316 UNI EN10088	Brass CW617N (OT58)	Stainless steel AISI316 UNI EN10088
06	Handwheel	Sheet of carbon steel	Sheet of carbon steel	Sheet of carbon steel
07	Handle	Steel A37 UNI EN10217-1	Steel A37 UNI EN10217-1	Steel A37 UNI EN10217-1
08	Gasket	Planiflex KG carbo/C PF81	Planiflex KG carbo/C PF81	Planiflex KG carbo/C PF81
09	Packing	Carbograph GR8800	Carbograph GR8800	Carbograph GR8800

Nota: Combinazioni materiali non standard a richiesta
 Note: Non standard materials combinations on request