

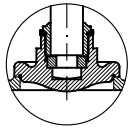

Conform to:
UNI EN1092
DIN 3202

Esecuzione 01
 con otturatore Com.



Execution 01
 with SDSL disc

Esecuzione 02
 con otturatore Aut.

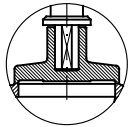

Execution 02
 with SDNR disc

con Proximity limit switch (a richiesta)
 with Proximity limit switch (on request)

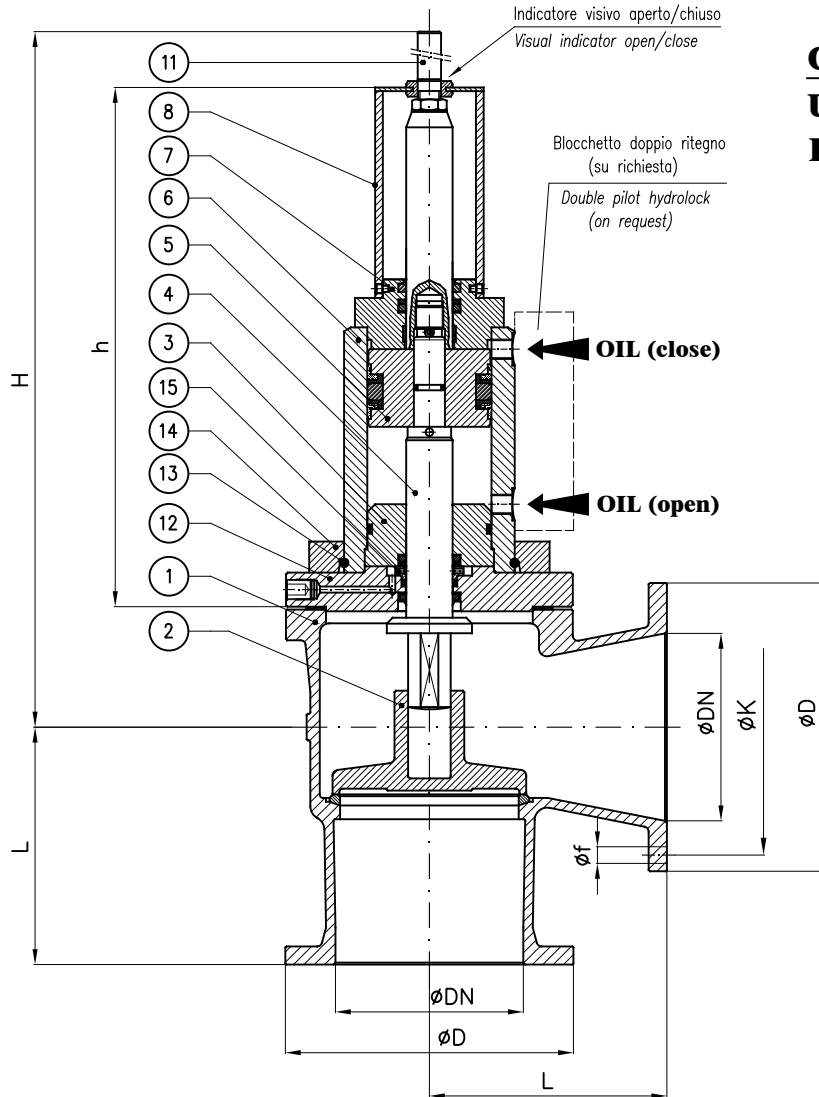
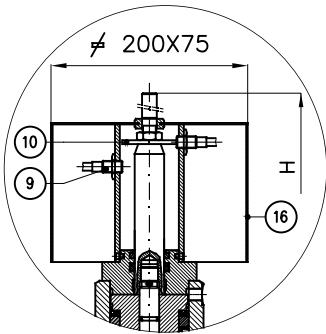

N.B.: Il dimensionamento e quindi anche l'ingombro dell'attuatore è funzione dei seguenti dati che devono sempre essere forniti:

- Pressione esercizio della valvola
- pressione olio all'attuatore
- Servizio

Note.: The size and so the overall dimension of the actuator depends by the following informations that should always be provided:

- Valve's working pressure
- Oil pressure to actuator
- Service

DN	h (~)	H (~)	L	Weight (Kg)	PN10DIN				PN16			
					øD	K	f	Holes NO. f	øD	K	f	Holes NO. f
20	210	265	85		105	75	14	4	105	75	14	4
25	210	270	90		115	85	14	4	115	85	14	4
32	335	415	105		140	100	18	4	140	100	18	4
40	335	420	115		150	110	18	4	150	110	18	4
50	320	420	125		165	125	18	4	165	125	18	4
65	315	420	145		185	145	18	4	185	145	18	4
80	340	445	155		200	160	18	8	200	160	18	8
100	340	455	175		220	180	18	8	220	180	18	8
125	360	495	200		250	210	18	8	250	210	18	8
150	360	505	225		285	240	22	8	285	240	22	8
200	440	655	275		340	295	22	8	340	295	22	12
250	440	660	325		395	350	22	12	405	355	26	12
300	525	850	375		445	400	22	12	460	410	26	12

Combinazione materiali standard - Standard materials Combination			
ITEM	DENOMINAZIONE DENOMINATION	G/316 MATERIALE MATERIAL	G/B MATERIALE MATERIAL
01	Body	Cast iron UNI EN1561 EN-GJL-250	Cast iron UNI EN1561 EN-GJL-250
02	Disc (≤ DN80)	Stainless steel AISI316 UNI EN10088	Bronze UNI EN1982 G-CuSn5Zn5Pb5
02	Disc (≥ DN100)	Cast steel GP240-GH UNI EN10213 plus AISI316 facing welding	Bronze UNI EN1982 G-CuSn5Zn5Pb5
03	Inner head flange	Cast iron UNI EN1561 EN-GJL-250	Cast iron UNI EN1561 EN-GJL-250
04	Stem	Stainless steel AISI316 UNI EN10088	Stainless steel AISI316 UNI EN10088
05	Piston	Steel 9SMnPb28 UNI EN10087	Steel 9SMnPb28 UNI EN10087
06	Housing welded assembly	Fe52.2 GALVANIZED	Fe52.2 GALVANIZED
07	Head flange	Steel UNI C40	Steel UNI C40
08	Proximity switch support	Fe37 GALVANIZED	Fe37 GALVANIZED
09	Proximity switch	CEED BG12/2PF2 PNP CEOM E2FX2E2G NPN	CEED BG12/2PF2 PNP CEOM E2FX2E2G NPN
10	Indicator washer	Steel 9SMnPb28 UNI EN10087	Steel 9SMnPb28 UNI EN10087
11	Index open/close	Brass CW617N (OT58)	Brass CW617N (OT58)
12	Flange	Steel UNI C40	Steel UNI C40
13	Snap ring ø5	Stainless steel AISI316 UNI EN10088	Stainless steel AISI316 UNI EN10088
14	Collar	Fe52.2 GALVANIZED	Fe52.2 GALVANIZED
15	Back rod	Steel 9SMnPb28 UNI EN10087	Steel 9SMnPb28 UNI EN10087
16	Shield	Stainless steel AISI316 UNI EN10088	Stainless steel AISI316 UNI EN10088

Note: Combinazioni materiali non standard a richiesta
 Note: Non standard materials combinations on request