

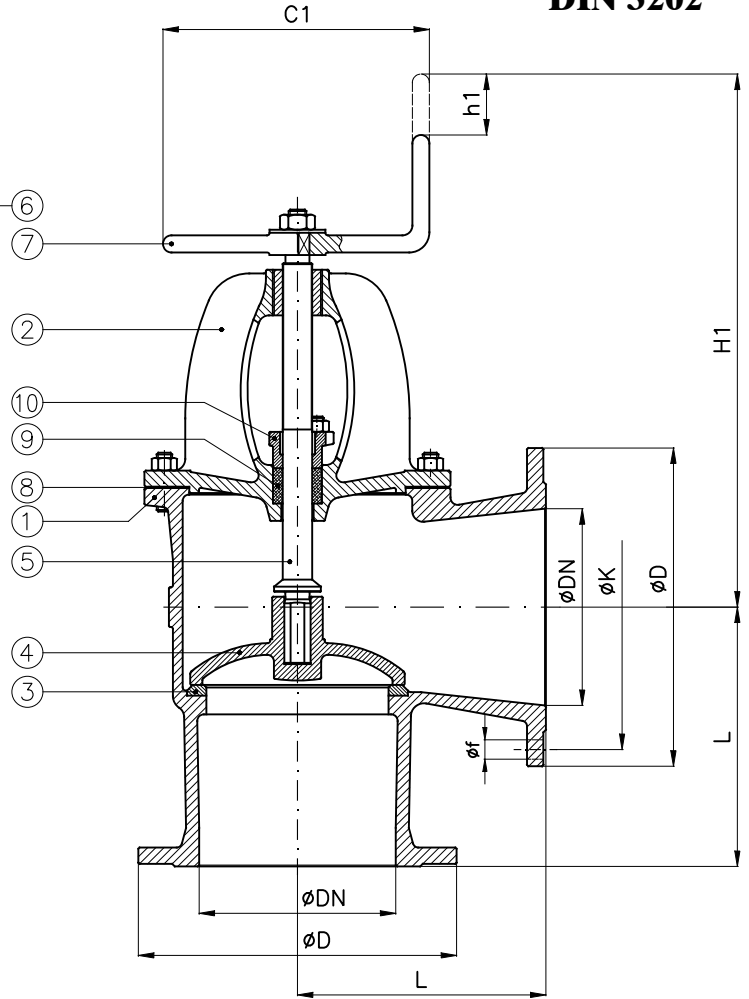

Conform to:
UNI EN1092
DIN 3202

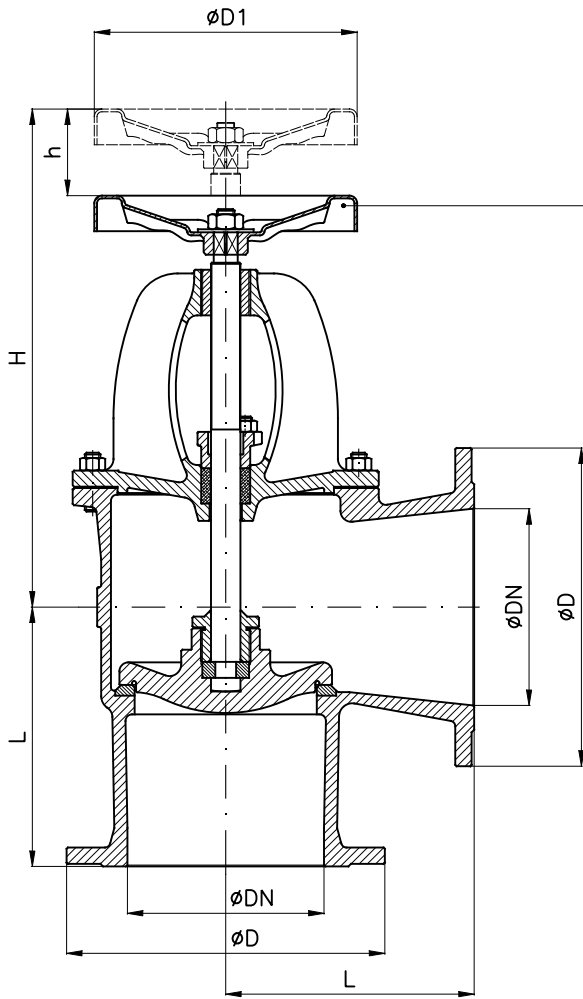

Tab.127A-SDSL TYPE PN10DIN PN16
 comandata (SDSL) with fixed disc (SDSL) - UNAV 9834

Tab.127A-SDNR TYPE PN10DIN PN16
 semiautomatica (SDNR) with loose disc (SDNR) - UNAV 9837

DN	C1	D1	H SDSL (~)	h SDSL	H1 SDNR (~)	h1 SDNR	L	Weight (Kg)	PN10DIN				PN16			
									D	K	f	Holes NO. f	D	K	f	Holes NO. f
15	100	100	195	12	220	8	85	5.5	95	65	14	4	95	65	14	4
20	100	100	195	12	220	8	85	6	105	75	14	4	105	75	14	4
25	100	100	210	14	235	9	90	7	115	85	14	4	115	85	14	4
32	125	125	225	17	250	10	105	10.5	140	100	18	4	140	100	18	4
40	125	125	235	20	255	12	115	11.5	150	110	18	4	150	110	18	4
50	125	125	245	24	265	14	125	13.5	165	125	18	4	165	125	18	4
65	175	175	325	32	340	18	145	26	185	145	18	4	185	145	18	4
80	175	175	335	35	355	20	155	30	200	160	18	8	200	160	18	8
100	200	200	365	45	365	28	175	37	220	180	18	8	220	180	18	8
125	225	225	425	54	430	32	200	60	250	210	18	8	250	210	18	8
150	225	300	475	62	485	38	225	74	285	240	22	8	285	240	22	8
175	250	400	505	74	505	45	250	100	315	270	22	8	315	270	22	8
200	250	400	570	82	600	50	275	128	340	295	22	8	340	295	22	12
250	300	500	645	100	665	66	325	206	395	350	22	12	405	355	26	12
300	425	575	665	118	675	85	375	245	445	400	22	12	460	410	26	12
350	500		720	130	795	90	400	360	505	460	22	16	520	470	26	16
400	575		900	135	915	100	450	417	565	515	26	16	580	525	30	16
450	650		955	160		115	500	540	615	565	26	20	640	585	30	20
500			1120	180	1160	130	535	850	670	620	26	20	715	650	33	20
600				215		160	550	1500	780	725	30	20	840	770	36	20

Combinazione materiali standard - Standard materials Combination				
ITEM	DENOMINAZIONE DENOMINATION	A/316 MATERIALE MATERIAL	A/B MATERIALE MATERIAL	CF8M/316 MATERIALE MATERIAL
01	Body	Cast steel GP240-GH UNI EN10213	Cast steel GP240-GH UNI EN10213	Stainless steel CF8M ASTM A351
02	Bonnet	Cast steel GP240-GH UNI EN10213	Cast steel GP240-GH UNI EN10213	Stainless steel CF8M ASTM A351
03	Body seat	Stainless steel AISI316 UNI EN10088	Stainless steel AISI316 UNI EN10088	Stainless steel AISI316 UNI EN10088
04	Disc (≤ DN80)	Stainless steel AISI316 UNI EN10088	Bronze UNI EN1982 G-CuSn5Zn5Pb5	Stainless steel AISI316 UNI EN10088
04	Disc (≥ DN100)	Cast steel GP240-GH UNI EN10213 plus AISI316 facing welding	Bronze UNI EN1982 G-CuSn5Zn5Pb5	Stainless steel CF8M ASTM A351
05	Stem	Stainless steel AISI316 UNI EN10088	Brass CW617N (OT58)	Stainless steel AISI316 UNI EN10088
06	Handwheel	Sheet of carbon steel	Sheet of carbon steel	Sheet of carbon steel
07	Handle	Steel A37 UNI EN10217-1	Steel A37 UNI EN10217-1	Steel A37 UNI EN10217-1
08	Gasket	Planiflex KG carbo/C PF81	Planiflex KG carbo/C PF81	Planiflex KG carbo/C PF81
09	Packing	Carbograph GR8800	Carbograph GR8800	Carbograph GR8800
10	Gland bushing	Steel Fe360B (S235JRC) UNI EN10025	Steel Fe360B (S235JRC) UNI EN10025	Stainless steel AISI316 UNI EN10088

Nota: Combinazioni materiali non standard a richiesta
Note: Non standard materials combinations on request