



Valvole ad angolo retto PN6 con attuatore idraulico doppio effetto

Angle valves NP6 with hydraulic double acting actuator

Tab.123G-DA

Esecuzione 01
con otturatore Com.

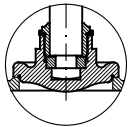

Execution 01
with SDSL disc

Esecuzione 02
con otturatore Aut.



Execution 02
with SDNR disc

con Proximity limit switch (a richiesta)
with Proximity limit switch (on request)

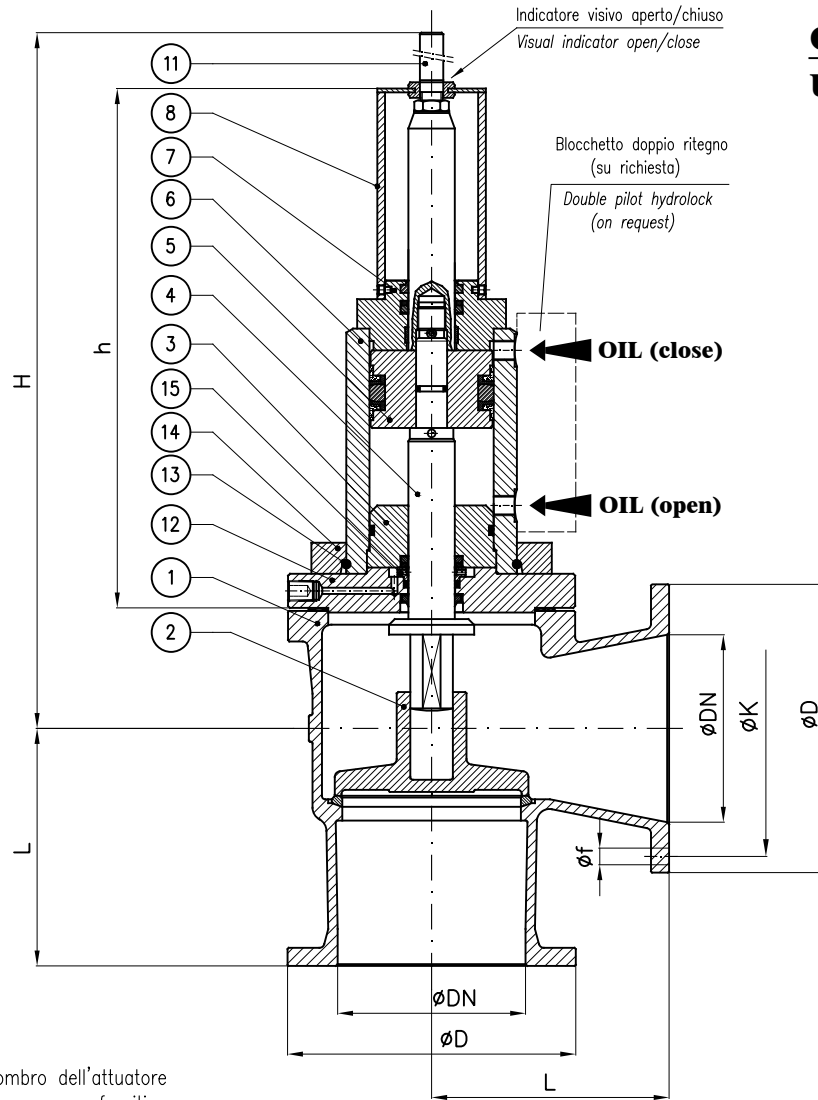
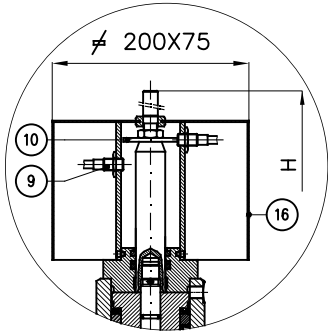

Conform to:
UNI EN1092

N.B.: Il dimensionamento e quindi anche l'ingombro dell'attuatore è funzione dei seguenti dati che devono sempre essere forniti:

- Pressione esercizio della valvola
- pressione olio all'attuatore
- Servizio

Note.: The size and so the overall dimension of the actuator depends by the following informations that should always be provided:

- Valve's working pressure
- Oil pressure to actuator
- Service

DN	h (~)	H (~)	L	ØD	K	f	Holes NO. f	Weight (Kg)
20	210	265	85	90	65	11	4	
25	210	270	90	100	75	11	4	
32	335	415	105	120	90	14	4	
40	335	420	95	130	100	14	4	
50	320	420	100	140	110	14	4	
65	315	420	120	160	130	14	4	
80	340	445	130	190	150	18	4	
100	340	455	150	210	170	18	4	
125	360	495	175	240	200	18	8	
150	360	505	200	265	225	18	8	
200	440	655	250	320	280	18	8	
250	440	660	300	375	335	18	12	
300	525	850	350	440	395	22	12	

Combinazione materiali standard - Standard materials Combination			
ITEM	DENOMINAZIONE DENOMINATION	G/316 MATERIALE MATERIAL	G/B MATERIALE MATERIAL
01	Body	Cast iron UNI EN1561 EN-GJL-250	Cast iron UNI EN1561 EN-GJL-250
02	Disc (≤ DN80)	Stainless steel AISI316 UNI EN10088	Bronze UNI EN1982 G-CuSn5Zn5Pb5
02	Disc (≥ DN100)	Cast steel GP240-GH UNI EN10213 plus AISI316 facing welding	Bronze UNI EN1982 G-CuSn5Zn5Pb5
03	Inner head flange	Cast iron UNI EN1561 EN-GJL-250	Cast iron UNI EN1561 EN-GJL-250
04	Stem	Stainless steel AISI316 UNI EN10088	Stainless steel AISI316 UNI EN10088
05	Piston	Steel 9SMnPb28 UNI EN10087	Steel 9SMnPb28 UNI EN10087
06	Housing welded assembly	Fe52.2 GALVANIZED	Fe52.2 GALVANIZED
07	Head flange	Steel UNI C40	Steel UNI C40
08	Proximity switch support	Fe37 GALVANIZED	Fe37 GALVANIZED
09	Proximity switch	CEED B612/2PF2 PNP CEOM E2FX2E2G NPN	CEED B612/2PF2 PNP CEOM E2FX2E2G NPN
10	Indicator washer	Steel 9SMnPb28 UNI EN10087	Steel 9SMnPb28 UNI EN10087
11	Index open/close	Brass CW617N (OT58)	Brass CW617N (OT58)
12	Flange	Steel UNI C40	Steel UNI C40
13	Snap ring Ø5	Stainless steel AISI316 UNI EN10088	Stainless steel AISI316 UNI EN10088
14	Collar	Fe52.2 GALVANIZED	Fe52.2 GALVANIZED
15	Back rod	Steel 9SMnPb28 UNI EN10087	Steel 9SMnPb28 UNI EN10087
16	Shield	Stainless steel AISI316 UNI EN10088	Stainless steel AISI316 UNI EN10088

Nota: Combinazioni materiali non standard a richiesta
Note: Non standard materials combinations on request