



Valvole ad angolo retto - serie pesante PN6

Angle valves - heavy class NP6

Tab.123G

Conform to:
UNI EN1092

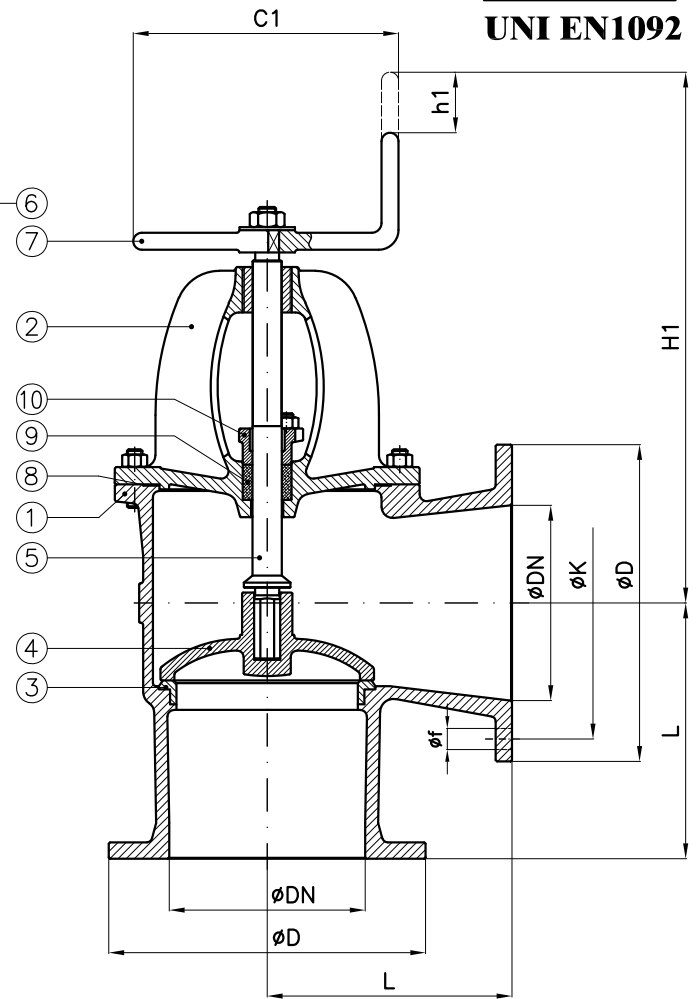
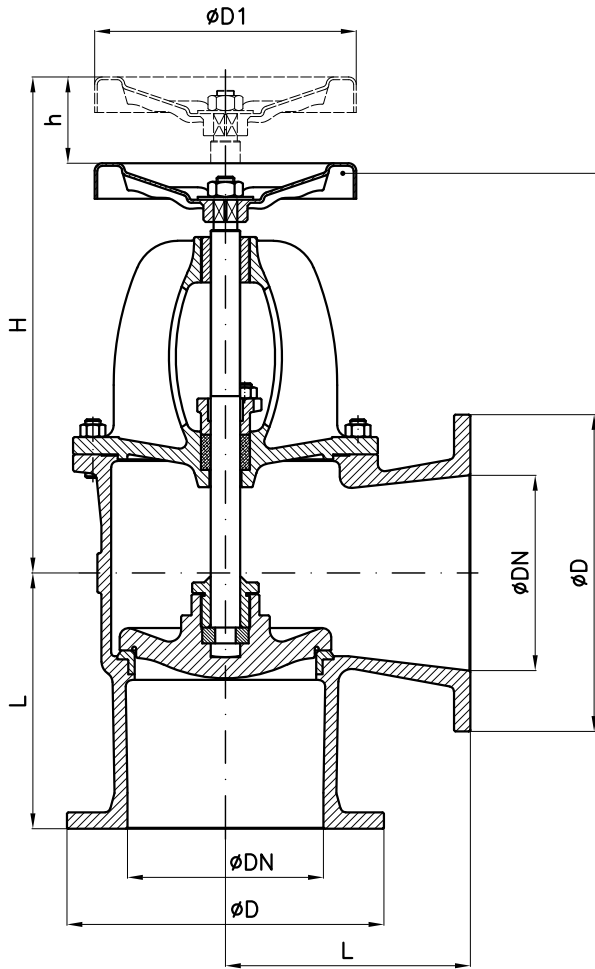

Tab.123.1G PN6
comandata (SDSL) UNI 3419
with fixed disc (SDSL) UNAV 8415

Tab.123.2G PN6
semiautomatica (SDNR) UNI 3423
with loose disc (SDNR) UNAV 8423

DN	C1	D1	H SDSL (~)	h SDSL	H1 SDNR (~)	h1 SDNR	L	D	K	f	Holes No. f	Weight (Kg)
40	125	125	230	20	255	12	95	130	100	14	4	10
50	125	125	230	24	255	14	100	140	110	14	4	11
65	175	175	290	32	310	18	120	160	130	14	4	16.5
80	175	175	300	35	325	20	130	190	150	18	4	21
100	200	200	345	45	345	28	150	210	170	18	4	29
125	225	225	380	54	390	32	175	240	200	18	8	46
150	225	300	405	62	420	38	200	265	225	18	8	60
175	250	400	470	74	490	45	230	295	255	18	8	81
200	250	400	500	82	510	50	250	320	280	18	8	96
250	300	500	585	100	570	66	300	375	335	18	12	151
300	425	575	680	118	680	85	350	440	395	22	12	228
350	500		805	130	845	90	400	490	445	22	12	355
400	575		910	135	915	100	450	540	495	22	16	400
450	650		950	160	1000	115	500	595	550	22	16	538
500				180		130	520	645	600	22	20	
600				215		160	550	755	705	26	20	

Combinazione materiali standard - Standard materials Combination			
ITEM	DENOMINAZIONE DENOMINATION	G/316	G/B
		MATERIALE MATERIAL	MATERIALE MATERIAL
01	Body	Cast iron UNI EN1561 EN-GJL-250	Cast iron UNI EN1561 EN-GJL-250
02	Bonnet	Cast iron UNI EN1561 EN-GJL-250	Cast iron UNI EN1561 EN-GJL-250
03	Body seat	Stainless steel AISI316 UNI EN10088	Stainless steel AISI316 UNI EN10088
04	Disc (≤ DN80)	Stainless steel AISI316 UNI EN10088	Bronze UNI EN1982 G-CuSn5Zn5Pb5
04	Disc (≥ DN100)	Cast steel GP240-GH UNI EN10213 plus AISI316 facing welding	Bronze UNI EN1982 G-CuSn5Zn5Pb5
05	Stem	Stainless steel AISI316 UNI EN10088	Brass CW617N (OT58)
06	Handwheel	Sheet of carbon steel	Sheet of carbon steel
07	Handle	Steel A37 UNI EN10217-1	Steel A37 UNI EN10217-1
08	Gasket	Planiflex KG carbo/C PF81	Planiflex KG carbo/C PF81
09	Packing	Carbograph GR8800	Carbograph GR8800
10	Gland bushing	Bronze UNI EN1982 G-CuSn5Zn5Pb5	Bronze UNI EN1982 G-CuSn5Zn5Pb5

Nota: Combinazioni materiali non standard a richiesta
Note: Non standard materials combinations on request