

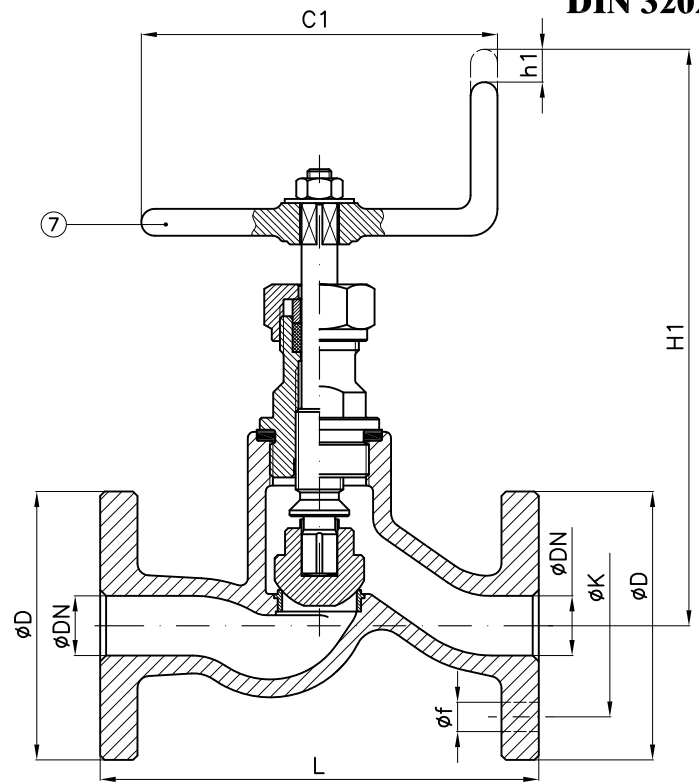

Conform to:
UNI EN1092
DIN 3202

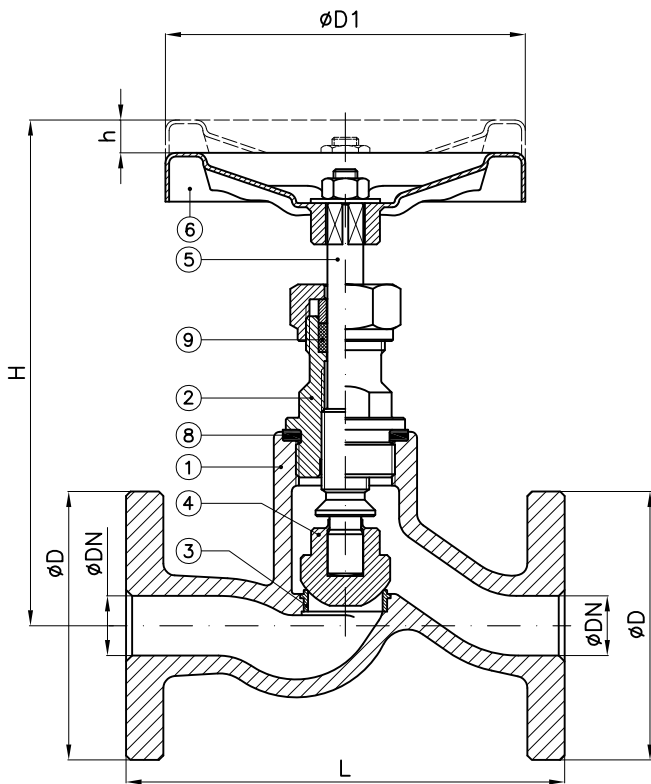

Tab.120.1G PN6
 comandata (SDSL) UNI 3409
 with fixed disc (SDSL) UNAV 8406

Tab.120.2G PN6
 semiautomatica (SDNR) UNI 3413
 with loose disc (SDNR) UNAV 8419

DN	C1	D1	H SDSL (~)	h SDSL	H1 SDNR (~)	h1 SDNR	L	D	K	f	Holes No. f	Weight (Kg)
15	100	100	170	10	200	10	150	80	55	11	4	3
20	100	100	170	10	200	10	150	90	65	11	4	3.5
25	100	100	170	10	200	10	160	100	75	11	4	4
32	125	125	205	13	235	13	180	120	90	14	4	5

Combinazione materiali standard – Standard materials Combination			
		G/316	G/B
ITEM	DENOMINAZIONE DENOMINATION	MATERIALE MATERIAL	MATERIALE MATERIAL
01	Body	Cast iron UNI EN1561 EN-GJL-250	Cast iron UNI EN1561 EN-GJL-250
02	Bonnet	Carbon steel GE240 UNI EN10293	Carbon steel GE240 UNI EN10293
03	Body seat	Stainless steel AISI316 UNI EN10088	Stainless steel AISI316 UNI EN10088
04	Disc	Stainless steel AISI316 UNI EN10088	Bronze UNI EN1982 G-CuSn5Zn5Pb5
05	Stem	Stainless steel AISI316 UNI EN10088	Brass CW617N (OT58)
06	Handwheel	Sheet of carbon steel	Sheet of carbon steel
07	Handle	Steel A37 UNI EN10217-1	Steel A37 UNI EN10217-1
08	Gasket	Planiflex KG carbo/C PF81	Planiflex KG carbo/C PF81
09	Packing	Carbograph GR8800	Carbograph GR8800

Nota: Combinazioni materiali non standard a richiesta
 Note: Non standard materials combinations on request