



**Valvole a globo PN10DIN-PN16 con attuatore idraulico semplice effetto normalmente aperto (FO)**

**Globe valves NP10DIN-NP16 with hydraulic single acting actuator fail open (FO)**

**Tab.126A-SR-FO**

( Ex Tab. 129/1-SR-FO )

**Conform to:  
UNI EN1092  
DIN 3202**

Esecuzione 01  
con attuatore Com.

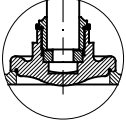

Execution 01  
with SDSL disc

Esecuzione 02  
con attuatore Aut.



Execution 02  
with SDNR disc

con Proximity limit switch (a richiesta)  
with Proximity limit switch (on request)

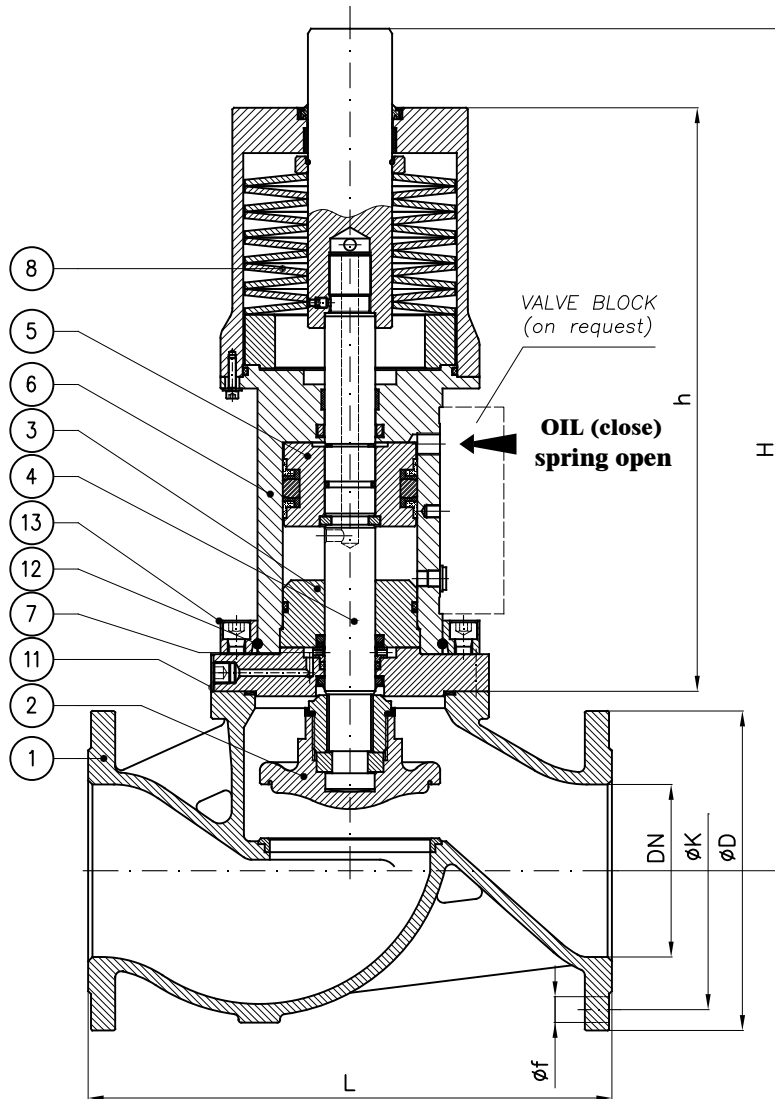
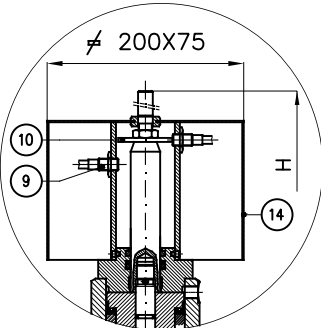

N.B.: Il dimensionamento e quindi anche l'ingombro dell'attuatore è funzione dei seguenti dati che devono sempre essere forniti:

- Pressione esercizio della valvola
- pressione olio all'attuatore
- Servizio

Note.: The size and so the overall dimension of the actuator depends by the following informations that should always be provided:

- Valve's working pressure
- Oil pressure to actuator
- Service

Combinazione materiali standard - Standard materials Combination				
ITEM	DENOMINAZIONE DENOMINATION	A/316 MATERIALE MATERIAL	A/B MATERIALE MATERIAL	CF8M/316 MATERIALE MATERIAL
01	Body	Cast steel GP240-GH UNI EN10213	Cast steel GP240-GH UNI EN10213	Stainless steel CF8M ASTM A351
02	Disc (≤ DN80)	Stainless steel AISI316 UNI EN10088	Bronze UNI EN1982 G-CuSn5Zn5Pb5	Stainless steel AISI316 UNI EN10088
02	Disc (≥ DN100)	Cast steel GP240-GH UNI EN10213 plus AISI316 facing welding	Bronze UNI EN1982 G-CuSn5Zn5Pb5	Cast steel GP240-GH UNI EN10213 plus AISI316 facing welding
03	Inner head flange	Cast iron UNI EN1561 EN-GJL-250	Cast iron UNI EN1561 EN-GJL-250	Cast iron UNI EN1561 EN-GJL-250
04	Stem	Stainless steel AISI316 UNI EN10088	Stainless steel AISI316 UNI EN10088	Stainless steel AISI316 UNI EN10088
05	Piston	Steel 9SMnPb28 UNI EN10087	Steel 9SMnPb28 UNI EN10087	Steel 9SMnPb28 UNI EN10087
06	Housing assembly	Fe52.2 GALVANIZED	Fe52.2 GALVANIZED	Fe52.2 GALVANIZED
07	Back rod	Steel 9SMnPb28 UNI EN10087	Steel 9SMnPb28 UNI EN10087	Steel 9SMnPb28 UNI EN10087
08	Disk spring	Steel UNI EN10270	Steel UNI EN10270	Steel UNI EN10270
09	Proximity switch	CEED BG12/2PF2 PNP CEOM E2FX2E2G NPN	CEED BG12/2PF2 PNP CEOM E2FX2E2G NPN	CEED BG12/2PF2 PNP CEOM E2FX2E2G NPN
10	Indicator washer	Steel 9SMnPb28 UNI EN10087	Steel 9SMnPb28 UNI EN10087	Steel 9SMnPb28 UNI EN10087
11	Flange	Steel UNI C40	Steel UNI C40	Steel UNI C40
12	Snap ring ø5	Stainless steel AISI316 UNI EN10088	Stainless steel AISI316 UNI EN10088	Stainless steel AISI316 UNI EN10088
13	Collar	Fe52.2 GALVANIZED	Fe52.2 GALVANIZED	Fe52.2 GALVANIZED
14	Shield	Stainless steel AISI316 UNI EN10088	Stainless steel AISI316 UNI EN10088	Stainless steel AISI316 UNI EN10088

Nota: Combinazioni materiali non standard a richiesta  
Note: Non standard materials combinations on request

DN	h (~)	H (~)	L	Weight (Kg)	PN10DIN				PN16			
					øD	K	f	Holes NO. f	øD	K	f	Holes NO. f
32	305	410	180		140	100	18	4	140	100	18	4
40	305	410	200		150	110	18	4	150	110	18	4
50	295	410	230		165	125	18	4	165	125	18	4
65	285	430	290		185	145	18	4	185	145	18	4
80	335	485	310		200	160	18	8	200	160	18	8
100	320	495	350		220	180	18	8	220	180	18	8
125	420	620	400		250	210	18	8	250	210	18	8
150	485	710	480		285	240	22	8	285	240	22	8
200	485	780	600		340	295	22	8	340	295	22	12
250	565	830	730		395	350	22	12	405	355	26	12